

PL	separator substancji ropopochodnych KLsepa.compact 3-300 zbiornik Saphir 900l, osadnik 300l, olej 300l, klasa II, NS3	kod	108100
narysowano ISC	waga: 80kg	www.grafpolska.pl info@grafpolska.pl	
data: sierpień 2017	tolerancja: +/- 3%		
skala: 1:20	jednostki: mm		

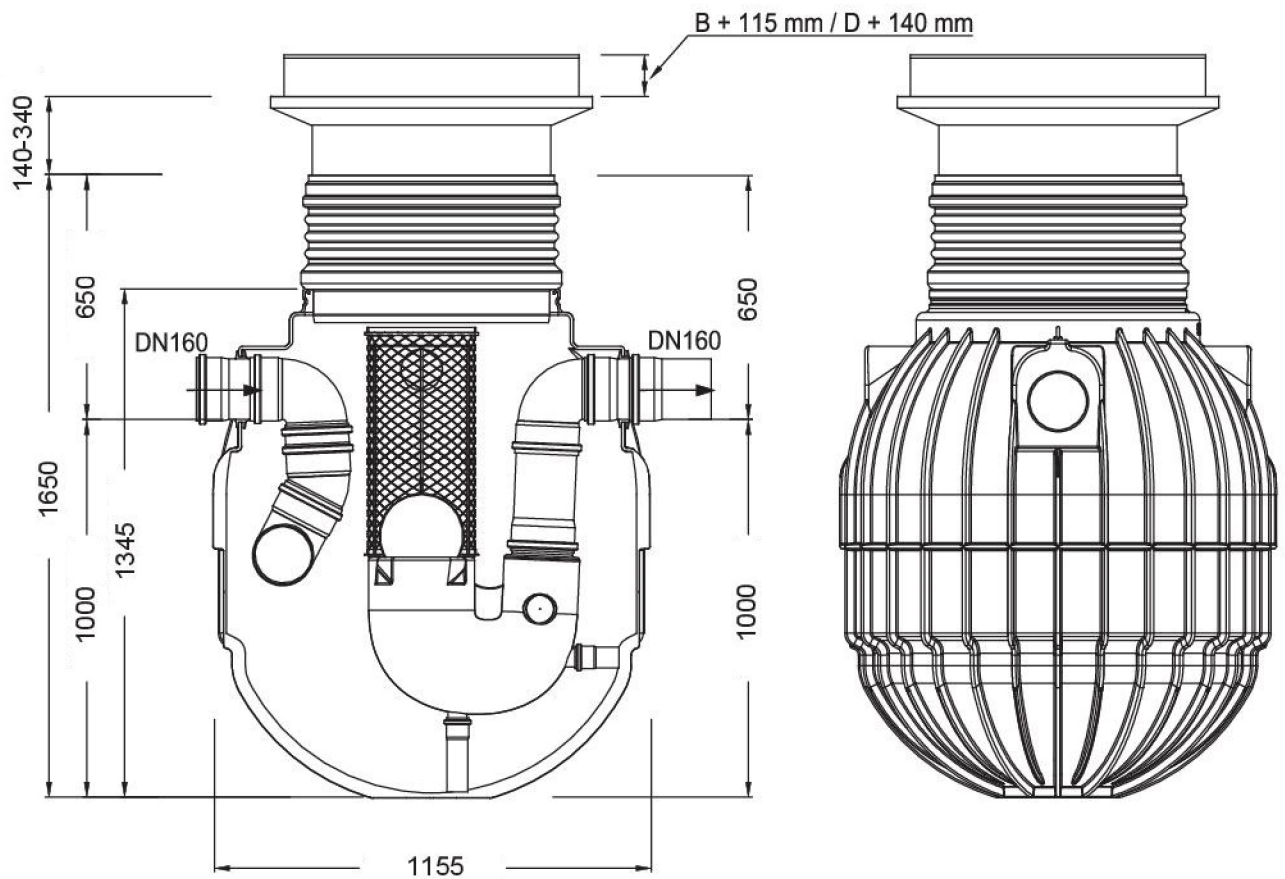
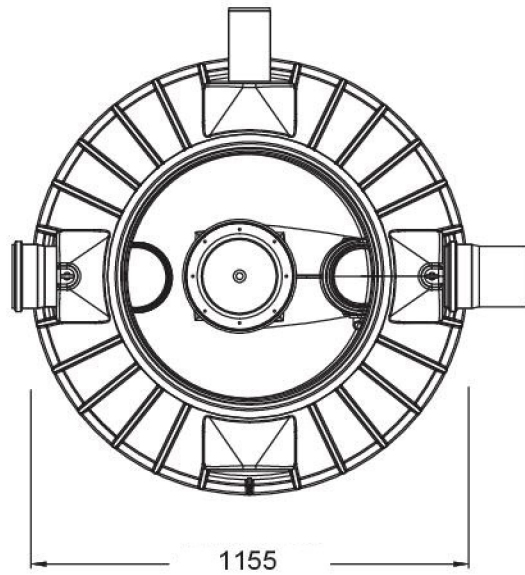

PL separator substancji ropopochodnych KLsepa.compact+ 3-300
zbiornik Saphir 900l, osadnik 300l, olej 300l, klasa I, NS3

kod
108101

narysowano ISC

waga: 80kg

data: sierpień 2017

tolerancja: +/- 3%

skala: 1:20

jednostki: mm

www.grafpolska.pl
info@grafpolska.pl



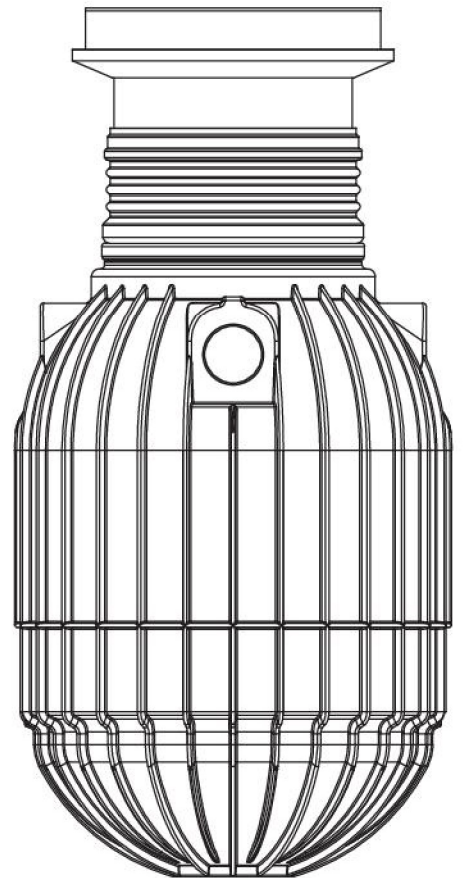
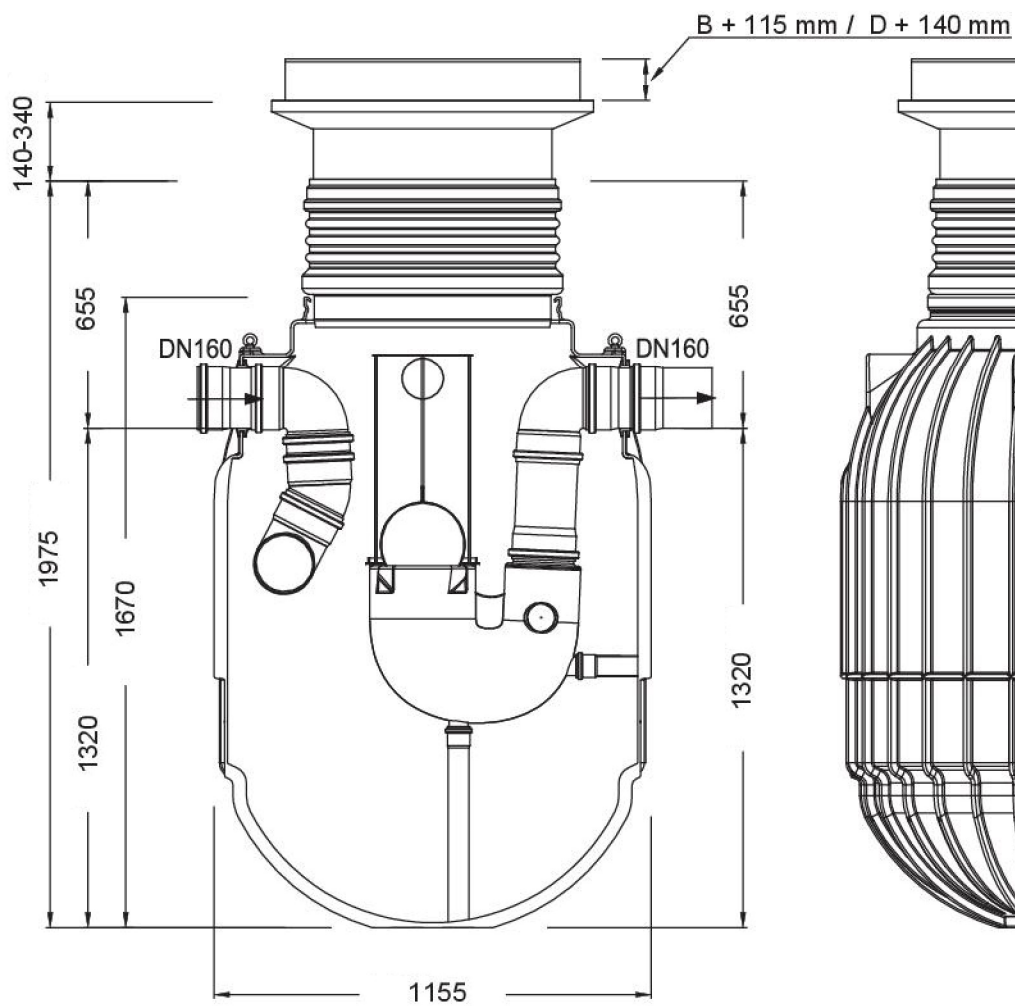
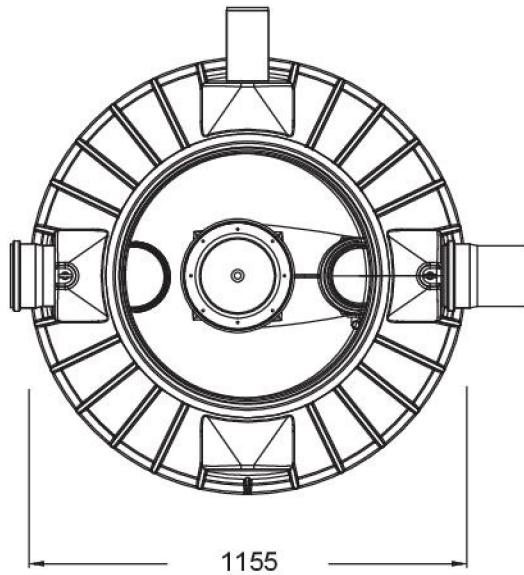

PL	separator substancji ropopochodnych KLsepa.compact 3-400 zbiornik Saphir 1200l, osadnik 400l, olej 500l, klasa II, NS3	kod	108102
narysowano ISC	waga: 110kg	www.grafpolska.pl info@grafpolska.pl	
data: sierpień 2017	tolerancja: +/- 3%		
skala: 1:20	jednostki: mm		

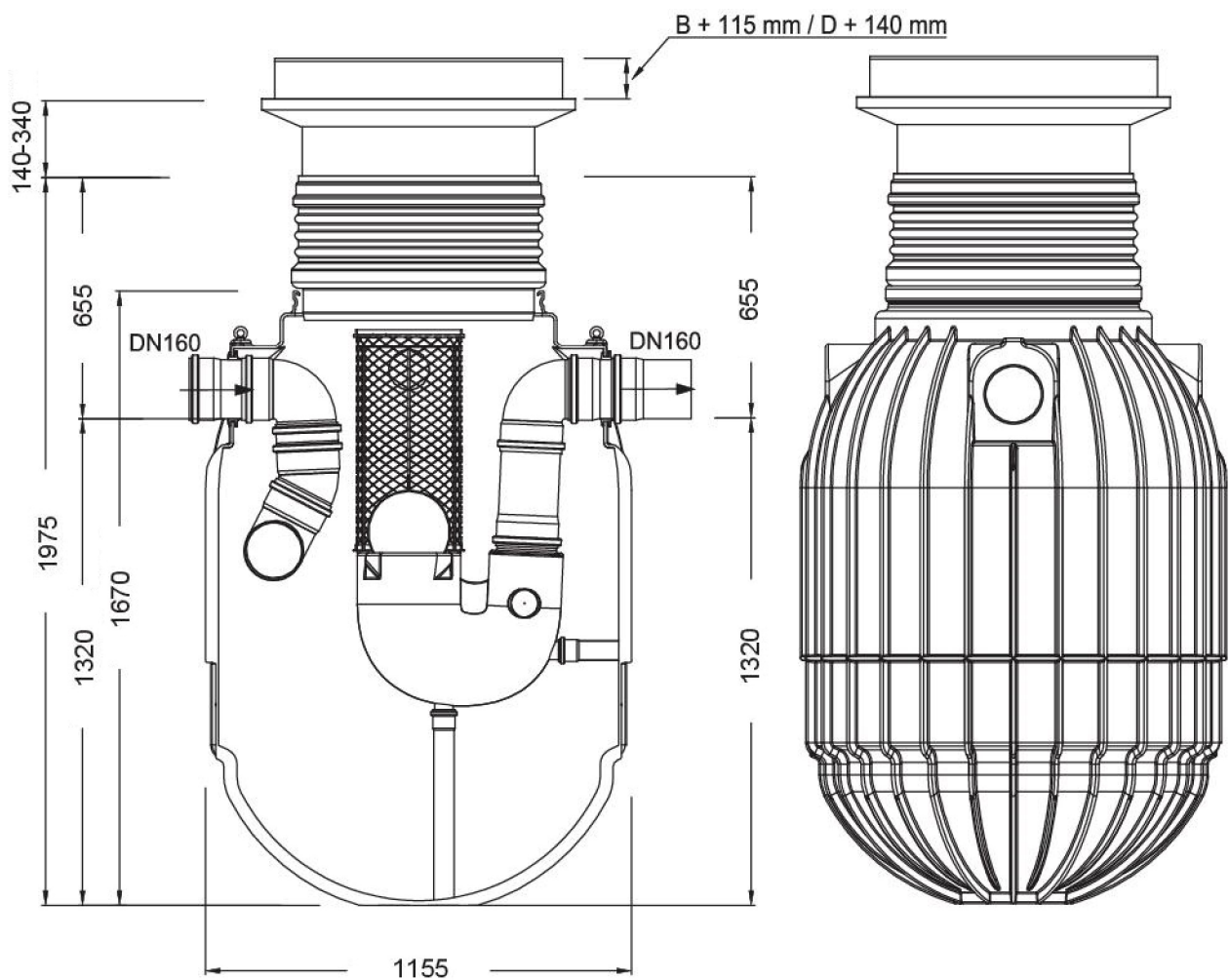
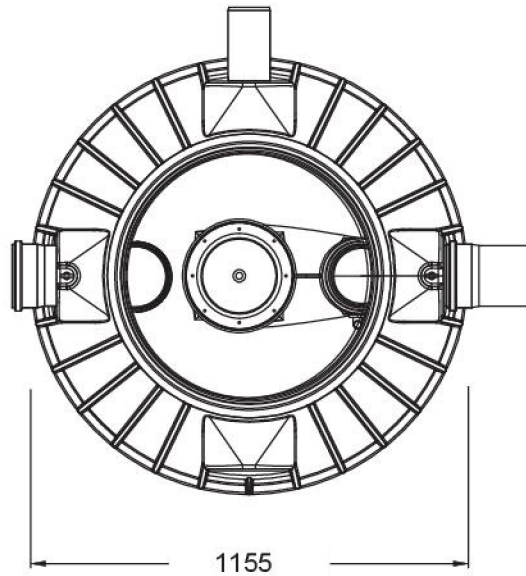

PL	separator substancji ropopochodnych KLsepa.compact+ 3-400 zbiornik Saphir 1200l, osadnik 400l, olej 500l, klasa I, NS3	kod	108103
narysowano ISC	waga: 110kg	www.grafpolska.pl info@grafpolska.pl	
data: sierpień 2017	tolerancja: +/- 3%		
skala: 1:20	jednostki: mm		

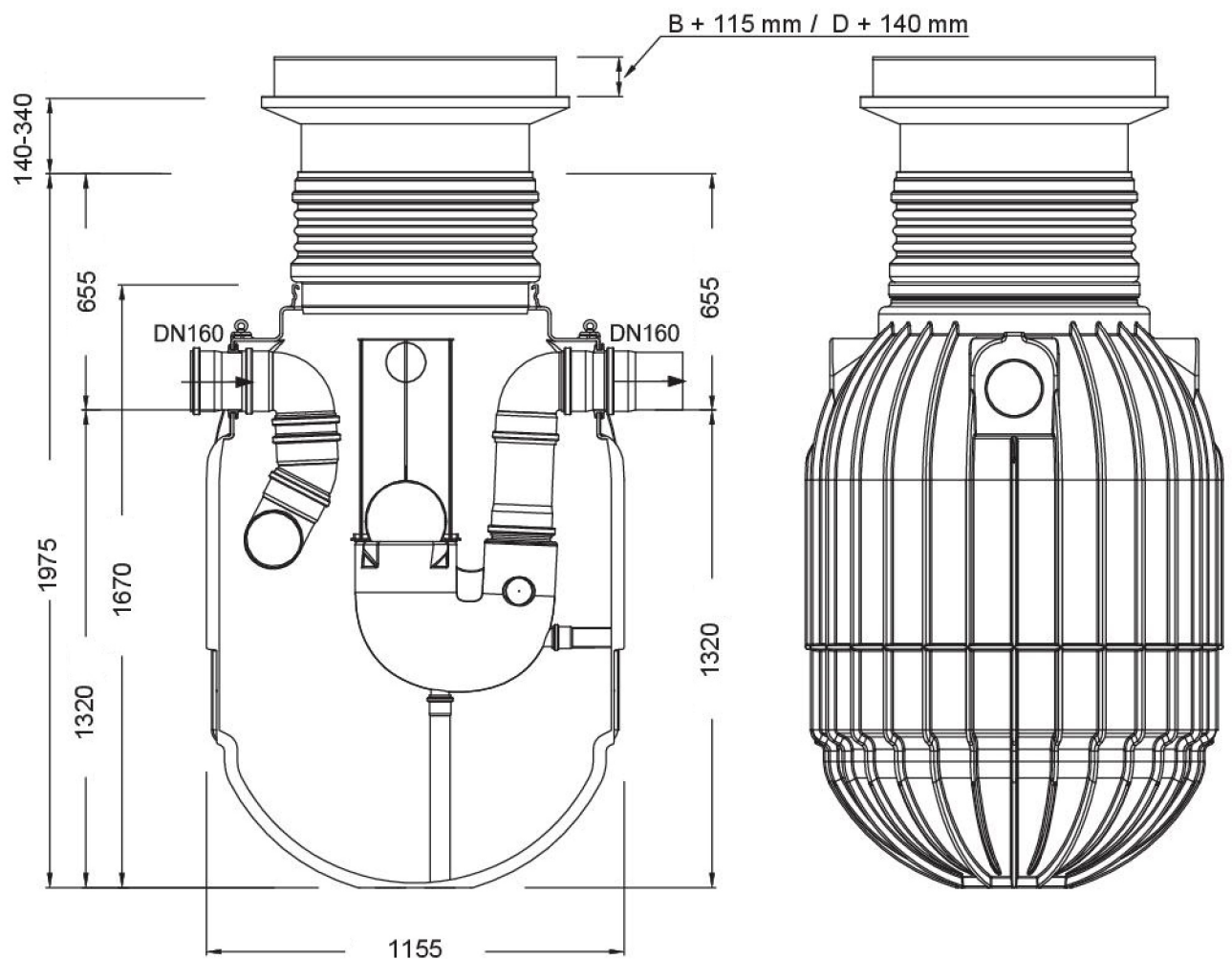
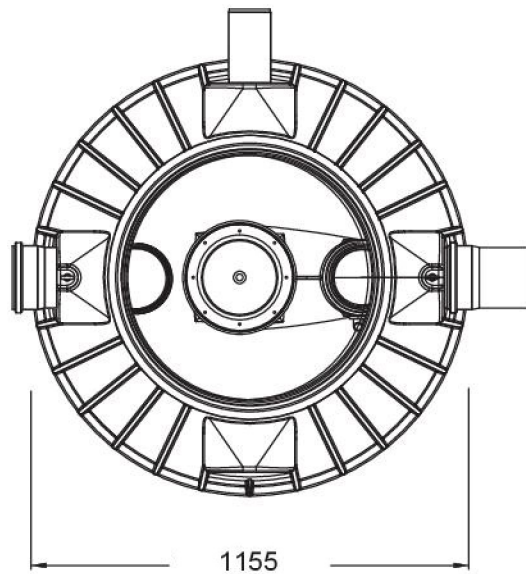

PL	separator substancji ropopochodnych KLsepa.compact 3-600 zbiornik Saphir 1200l, osadnik 600l, olej 300l, klasa II, NS3	kod 108104
narysowano ISC	waga: 110kg	www.grafpolska.pl info@grafpolska.pl 
data: sierpień 2017	tolerancja: +/- 3%	
skala: 1:20	jednostki: mm	

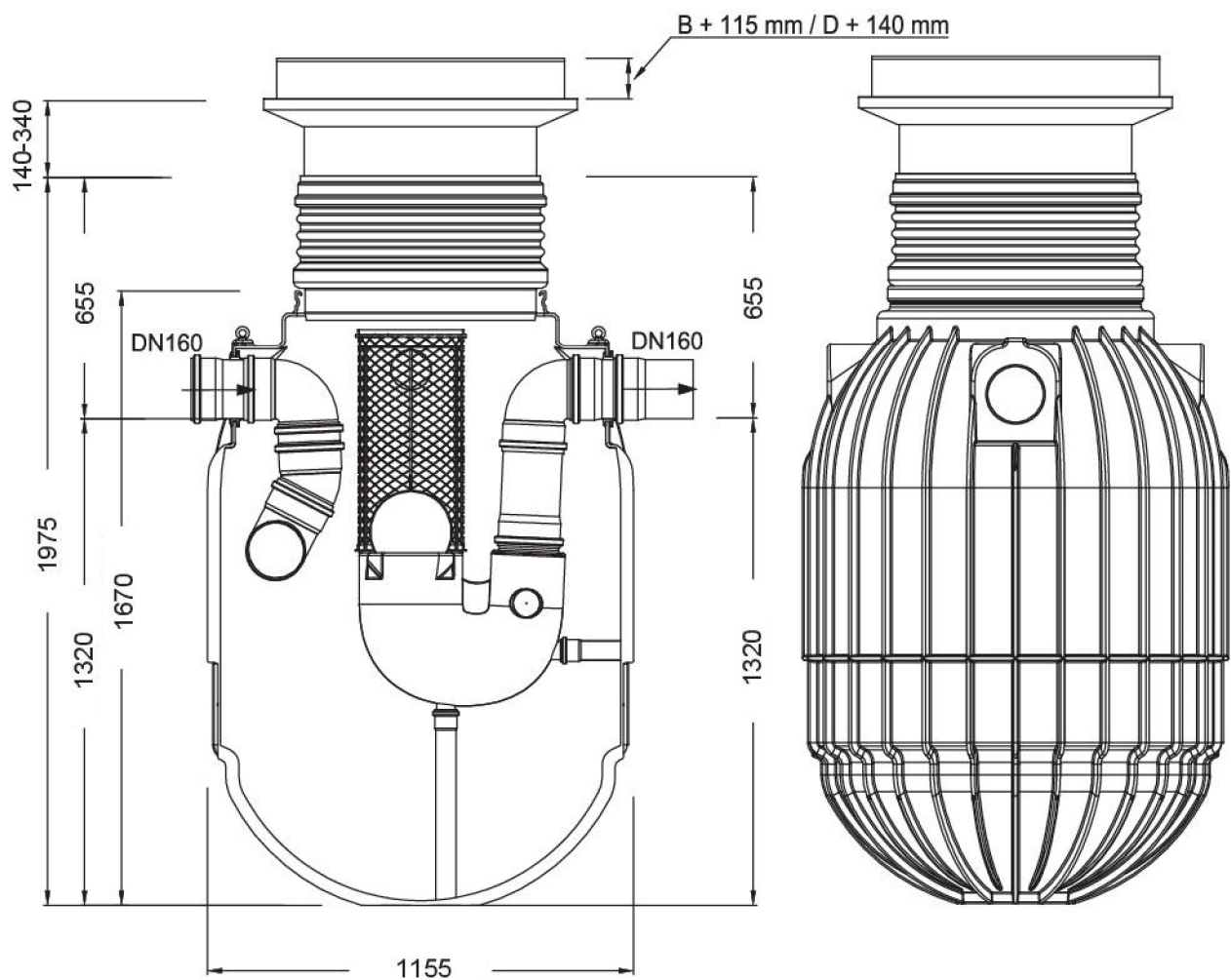
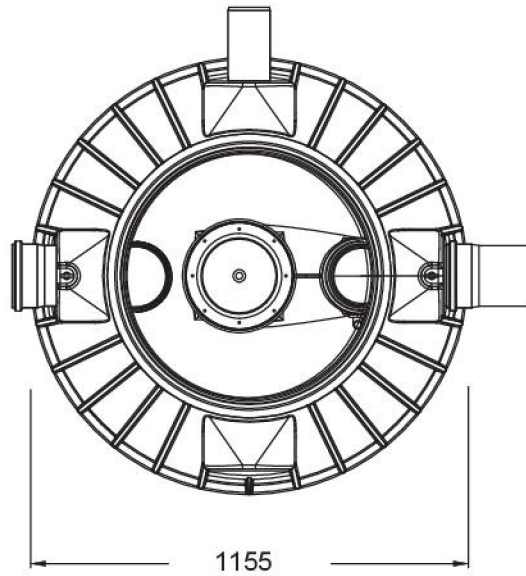

PL	separator substancji ropopochodnych KLsepa.compact+ 3-600 zbiornik Saphir 1200l, osadnik 600l, olej 300l, klasa I, NS3	kod	108105
narysowano	ISC	waga:	110kg
data:	sierpień 2017	tolerancja:	+/- 3%
skala:	1:20	jednostki:	mm
		www.grafpolska.pl info@grafpolska.pl	

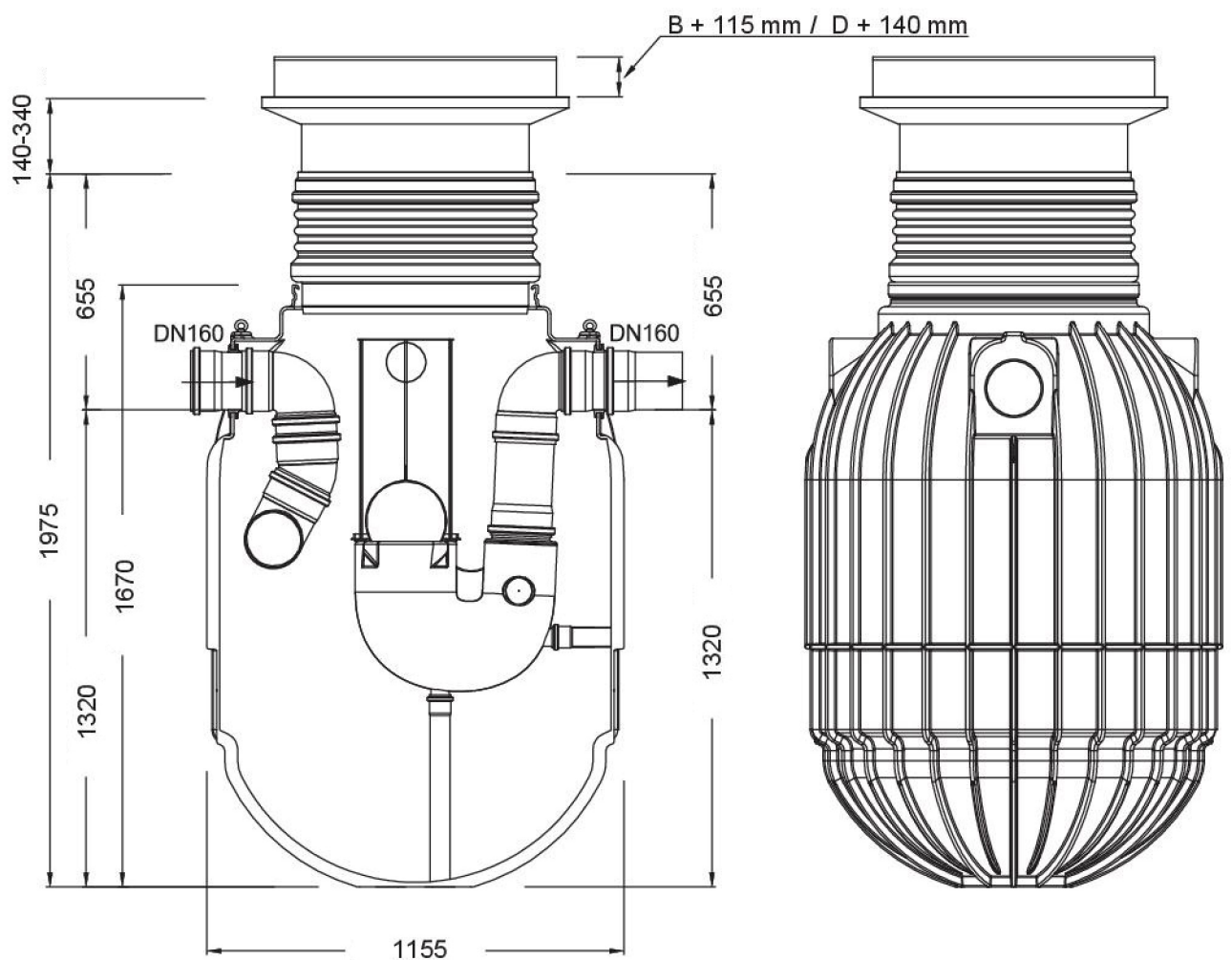
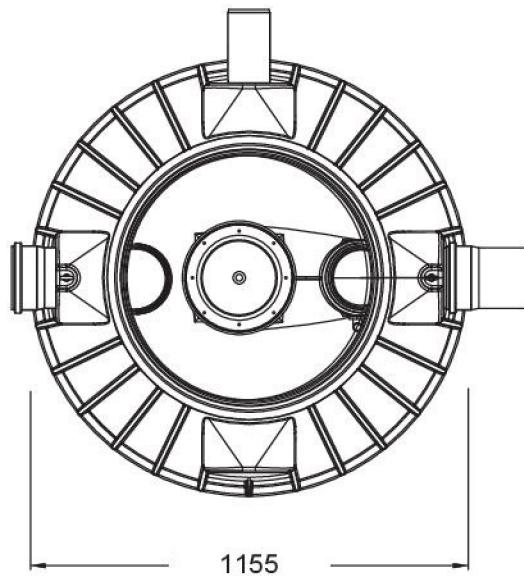

PL	separator substancji ropopochodnych KLsepa.compact 6-600 zbiornik Saphir 1200l, osadnik 600l, olej 300l, klasa II, NS6	kod	108106
narysowano ISC	waga: 110kg	www.grafpolska.pl info@grafpolska.pl	
data: sierpień 2017	tolerancja: +/- 3%		
skala: 1:20	jednostki: mm		

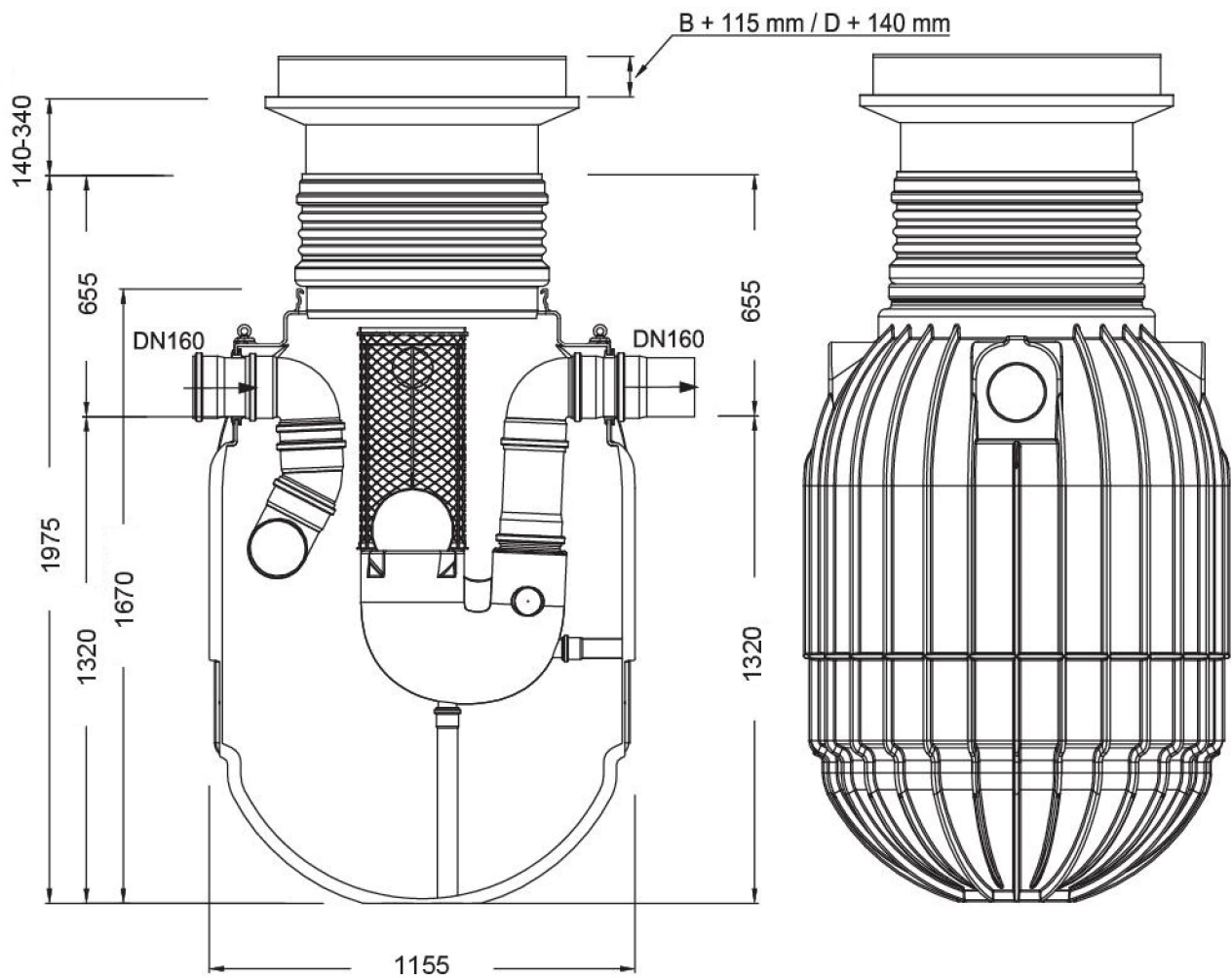
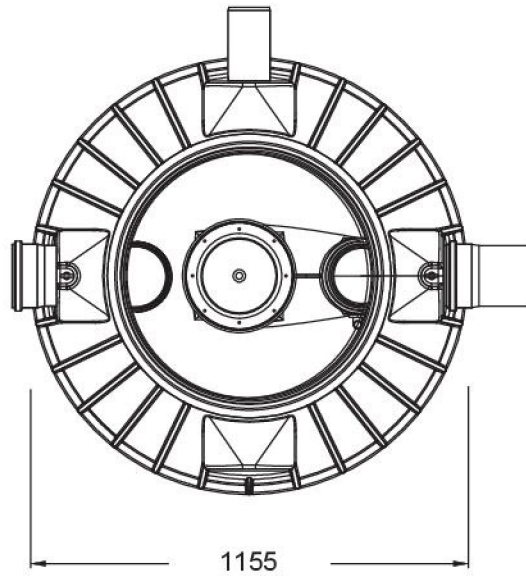

PL	separator substancji ropopochodnych KLsepa.compact+ 6-600 zbiornik Saphir 1200l, osadnik 600l, olej 300l, klasa I, NS6	kod	108107
narysowano ISC	waga: 110kg	www.grafpolska.pl info@grafpolska.pl	
data: sierpień 2017	tolerancja: +/- 3%		
skala: 1:20	jednostki: mm		